



ATTRACTIVE DESIGN: FLOATING FOUNTAINS STAGE THE BODY OF WATER DAY AND NIGHT

WATER IN ITS MOST BEAUTIFUL FORM – FOUNTAINS ARE NOT ONLY AN ATTRACTIVE HIGHLIGHT FOR ANY BODY OF WATER, THEY ARE ALSO HEALTHY FOR THE BIOLOGICAL BALANCE

OASE INNOVATION CENTER

Location: Hörstel
Appealing design and
functionality:
The new MIDI/MAXI
floating fountains.

OASE reference object, left

Floating fountains conjure up impressive water effects wherever standing aggregates are difficult to install: If there are fluctuating water levels, excessive water depths, or on muddy pond floors. Thanks to easy installation they can also be implemented on short notice, or the water pattern can be changed as desired.

The floating fountains stay on the surface without tipping, thanks to robust float elements. The foamed float element ensures ideal buoyancy of the floating fountains. Only the nozzle and the surface of the float element are visible; the technology remains concealed underwater.

Various easily interchangeable fountain nozzles are available for custom design of the water pattern of the floating fountains. LED illumination sets give the fountains a fascinating appearance in the evening hours.

OASE floating fountains make an additional contribution by enriching the oxygen in the body of water; a contribution toward the reduction of algae.



*Appealing design and functionality combined –
with floating fountains from OASE.*

• Floating fountains

Pond-Jet	page 62
Flexy Jet 6	page 64
Midi II/Maxi II	page 66
Fountain attachments	page 68
Illumination sets	page 70



Pond-Jet with Vulkan 37-2.5K | Pond-Jet with Pond-Jet-Nozzle

POND-JET

Thanks to the Pond-Jet floating fountain pump, decorative fountains can easily and quickly be achieved without any complex installation.

Neither the depth of the water, nor a pond base that is very dirty or difficult to access are of significance here. Perfect for use at short notice.

Product characteristics at a glance

- Ready-to-connect complete aggregate, consisting of pump, float element, and Pond-Jet-nozzle with 1"-thread
- Clearly structured fountain height and spray diameter of 3 metres
- Minimum water depth in clear water is 1 m; for a muddy pond floor the minimum depth is 1.5 m
- Lighting set and additional nozzle patterns are available as accessories
- 3 year guarantee



Accessories (must be ordered separately)



Pond-Jet illumination set	
Lunaqua 10 with 50 W each	3 x
Stainless steel holder	3 x
Transformer 150 VA	1 x
Cable length	20.0 m
Order no.	57083



Pond-Jet-nozzle
with 1"-thread, cover and plug.

1"-thread with nozzle
Here, as an example with a mounted Schaumsprudler 35-10E.



Connection possibility
of the underwater lighting
transformer.

Accessories: Lighting set
Three Lunaqua 10 spotlights –
must be ordered separately.

Pump performance curve

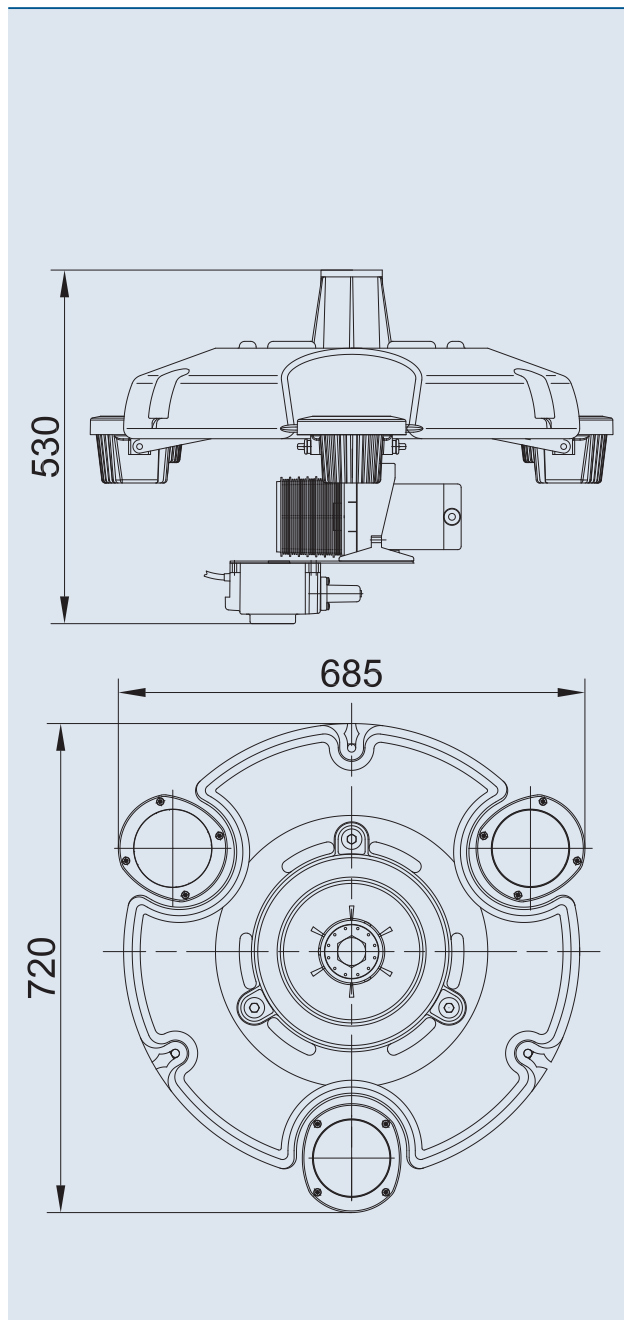
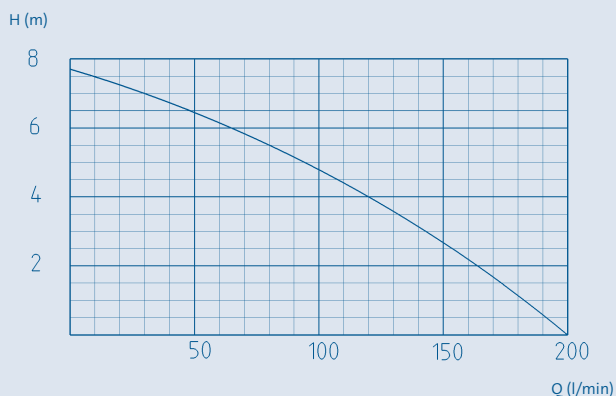

Accessories (must be ordered separately)

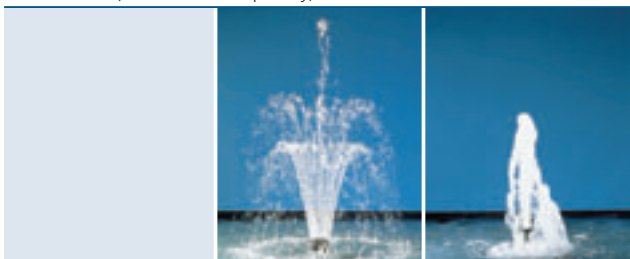

Fountain attachments with 1" thread for attachment to the multi-function nozzle

	Vulkan 37-2,5 K	Schaumsprudler 35-10 E
Fountain height [cm]	400	140
Order no.	52319	50984

	Pond-Jet
Dimensions (ø x H)	670 x 540 mm
Rated voltage	220 - 240 V / 50 Hz
Power consumption	270 W
Litres per minute max.	200 l/min.
Litres per hour max.	12000 l/h
Head height max.	7.7 m
Pressure-side connection	1"
Spray height	3.0 m
Filter surface area	650 cm ²
Cable length	20.0 m
Weight	approx. 11.0 kg
Order no.	57075



FLEXY JET 6

Floating Fountain Flexy Jet: A flexible fountain that comes with six Frothy nozzles and a pre-programmed software which allows the immediate operation of the impressive water display with a maximum height of 1.70 m.

The Flexy Jet 6 gets its power from the well-proven Varionaut 2 with a total of 780 W – for a low power consumption that saves energy. A frequency of 50 to 60 hz allows an application throughout the whole world.



Thanks to the Plug'n'Spray concept, installation is very easy and doesn't even require a professional electrician: only one 20 m cable connects the fountains to the electric power supply. The fastening system includes 2x 20 m steel cable, hooks and anchors. The scope of delivery also contains a switch box and the pre-programmed standard software controller.

An illumination set is available as an accessory. It includes 3x Lunaqua 10 Set (50 W halogen light each, underwater transformer UST 150 with 20 m cable) and all necessary equipment to fix these units with stainless steel holders at the Flexy Jet 6. Color lenses are also available.

Product characteristics at a glance

- Plug'n'Spray: Ready for installation with a 20 m cable
- Includes 6 Frothy Nozzles
- Water display of maximum 1.70 m in height
- Minimum water depth of only 23 cm
- Pre-programmed effects
- Protection class IP 68

Pump performance curve

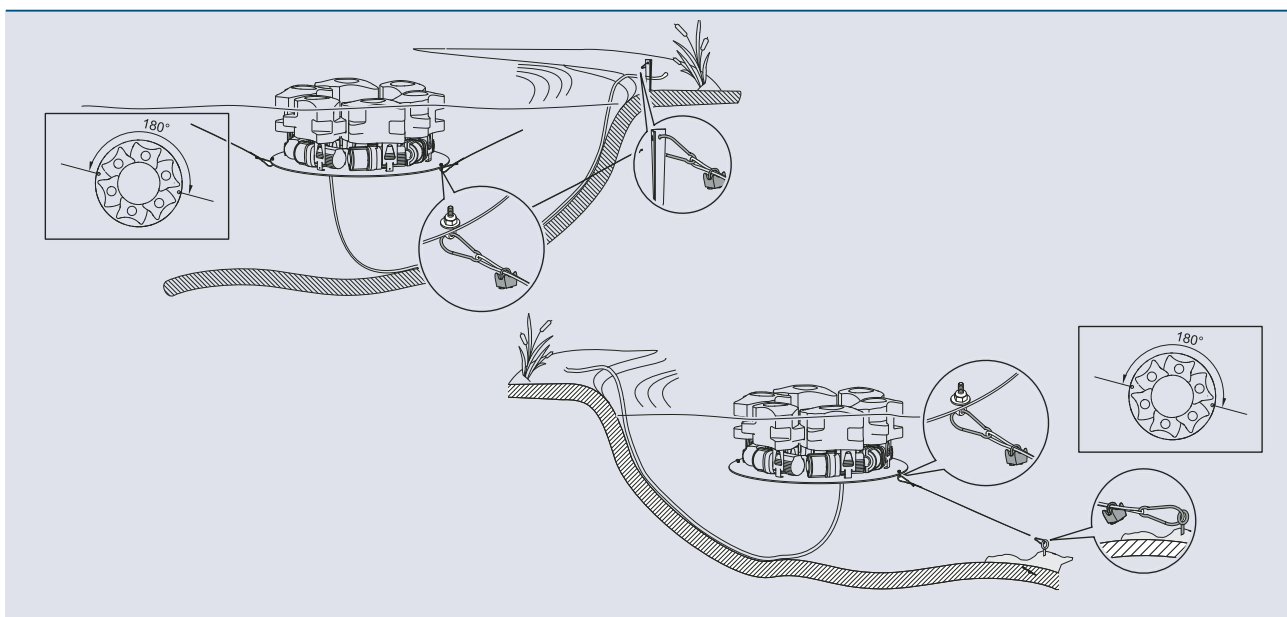
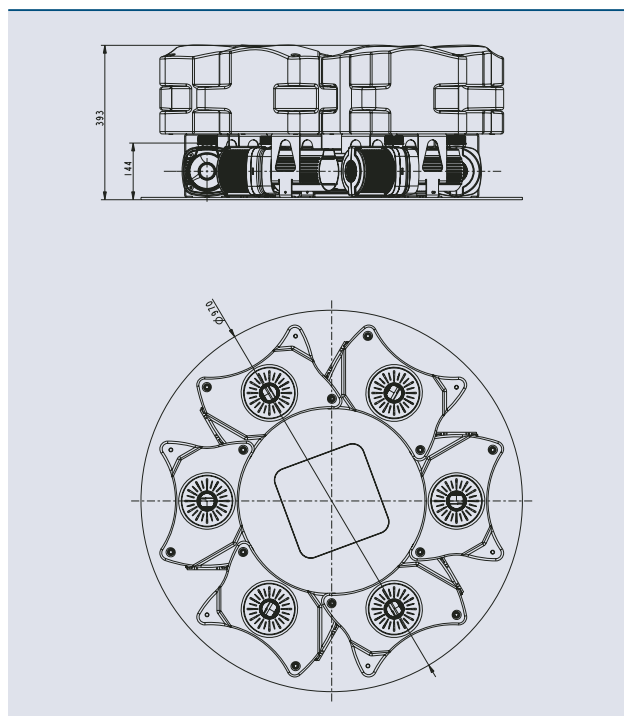
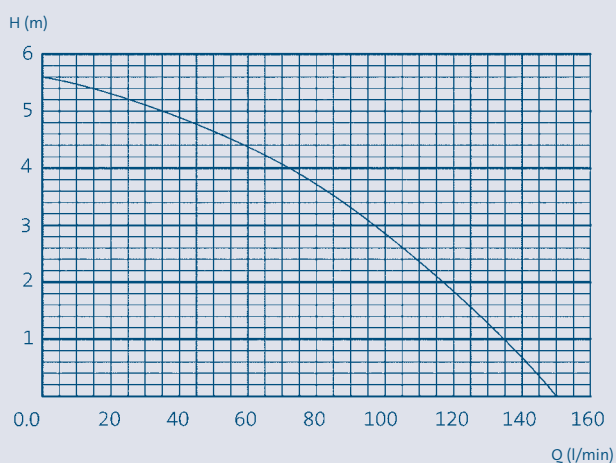

Accessories (must be ordered separately)



Flexy Jet illumination set	
Lunaqua 10 with 50 W each	3 x
Stainless steel holder	3 x
Transformer 150 VA	1 x
Cable length	20.0 m
Order no.	50212

Flexy Jet 6	
Dimensions (Ø x H)	940 x 450 mm
Nominal voltage	AC 220 - 240 V / 50-60 Hz
Power consumption	6 x 130 W / 1.3 A
Suction side connection	1.5"
Pressure side connection	1.5"
H max.	5.6 m
Q max.	6 x 150 l/min.
Input power	20m power cable with a schuco-plug
Protection class	IP 68
Max. fountain height with Schaumsprudler 35-10 E	1.7 m
Cable length	20.0 m
Weight	75.0 kg
Material	plastic/stainless steel
Order no.	50143



FLOATING FOUNTAIN MIDI II / MAXI II

Easy to install, low-maintenance and with an attractive design: The new MIDI/MAXI floating fountains feature four new nozzle patterns for interesting effects both day and night.

Three different motor power outputs with regulation-conformant earthed plugs (230 V) and motor circuit breaker or CEE plug (400 V)

offer solutions for different bodies of water and conditions. Optimised water pressure creates impressive heights for the four available nozzle patterns with 3" standard threads for fast changing. The easy-to-install Lunaqua 10 LED/01 illumination set provides for impressive lighting of the water pattern with a height of up to 16.5 m.

INNOVATION – MADE BY OASE



Product characteristics at a glance

- Complete, ready-to-connect fountain in three different motor output sizes with regulation-conformant earthed plug (230 V) and motor circuit breaker or CEE plug (400 V)
- Easy to install thanks to »Plug'n'Spray«
- Four easy-change nozzle patterns with 3" standard threads
- Lunaqua 10 LED/01 illumination system optional
- Includes mounting set
- Control cabinet on request



Schuko plugs + control box
The 230V version is delivered ready for operation with control box and Schuko connector.



CEE-connector + protection switch
The 400V version comes with a ready-to-connect, 5-pole CEE connector and motor protection switch

Pump performance curves

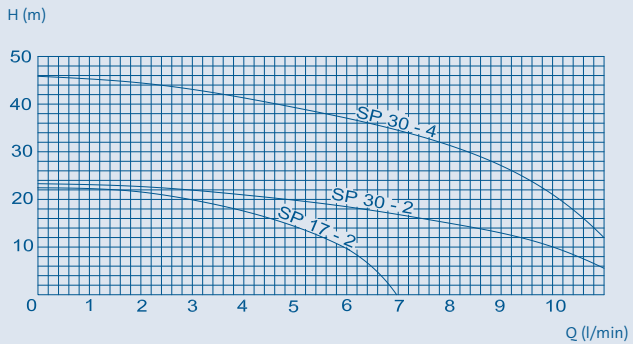

The graph plots head (H) in meters on the y-axis (0 to 50) against flow rate (Q) in liters per minute on the x-axis (0 to 10). Three curves are shown: SP 30-4 (highest head), SP 30-2 (middle head), and SP 17-2 (lowest head).

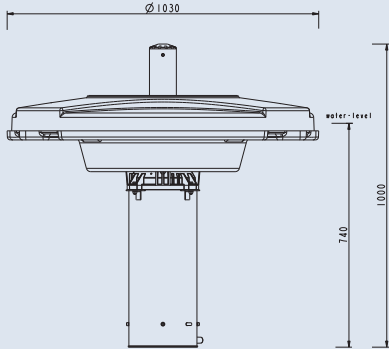

Dimensions: $\varnothing 1030$ (width), 740 (height to water level), 1000 (total height)

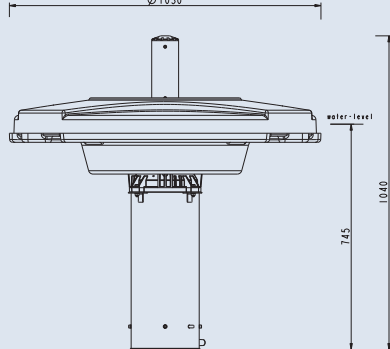

Dimensions: $\varnothing 1030$ (width), 745 (height to water level), 1040 (total height)

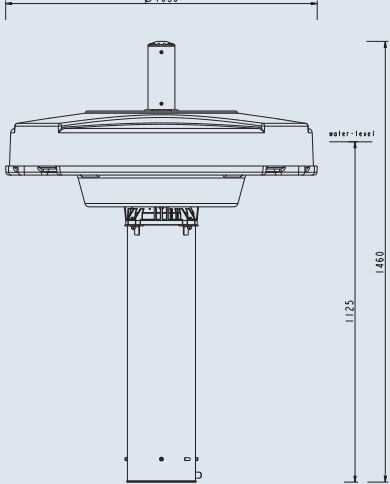

Dimensions: $\varnothing 1030$ (width), 1125 (height to water level), 1460 (total height)

Floating Fountain	MIDI II 1.1 KW / 230V	MIDI II 2.2 KW / 400V	MAXI II 4.0 KW / 400V
Dimensions incl. Nozzle (\varnothing x H) [mm]	1030x 1000	1030 x 1040	1030 x 1460
Motor power [kW]	1.1	2.2	4.0
Pump output [l/h]	22000	39000	39000
Minimum water depth [mm]	1000	1000	1250
Protection class	IP 68	IP 68	IP 68
Rated current (230V/400V) [A]	7.3	5.5	9.6
Voltage [V/Hz]	230 AC / 50	400 AC / 50	400 AC / 50
Weight [kg]	43	40	60
Pump cable set (length) [m]	50	50	50
Order no.	50365	50370	50371

MIDI II / MAXI II FOUNTAIN ATTACHMENTS



1



2



1



2



NEW



NEW

Fountain attachments	1 Nozzle High Jet 3'' Midi II / Maxi II			2 Nozzle Geysers Jet 3'' Midi II / Maxi II		
Pump power	1.1 kW/230 V	2.2 kW/400 V	4 kW/400 V	1.1 kW/230 V	2.2 kW/400 V	4 kW/400 V
Fountain height (total) [m]	9.0	11.5	16.5	5.0	8.0	12.0
Fountain height (1st step) [m]	–	–	–	–	–	–
Fountain diameter [m]	–	–	–	–	–	–
Order no.	50375			50377		

All MIDI/MAXI attachments comes with 3''-thread.

Please find more information on our floating fountains MIDI II/MAXI II on page 66.



3 Nozzle Grand Vulcan 3" Midi II / Maxi II			4 Nozzle Trumpet Jet 3" Midi II / Maxi II			Fountain attachments	
1.1 kW/230 V	2.2 kW/400 V	4 kW/400 V	1.1 kW/230 V	2.2 kW/400 V	4 kW/400 V	Pump power	
3.0	5.0	7.0	5.0	7.0	9.5	[m]	(total) Fountain height
–	–	–	1.2	1.5	2.5	[m]	(1st step) Fountain height
Ø 2.5	Ø 3.5	Ø 4.0	Ø 4.5	Ø 7.5	Ø 8.0	[m]	Fountain diameter
50376			50378			Order no.	

All MIDI/MAXI attachments comes with 3"-thread.

Please find more information on our floating fountains MIDI II/MAXI II on page 66.



ILLUMINATION SETS POND-JET / AIR FLO



Pond-Jet illumination sets

This illumination set includes three Lunaqua 10 halogen spotlights and comes with UST 150 transformers, cables and a special mounting kit.

By this, it is very easy to retrofit.



Pond-Jet

Air Flo illumination sets

Suitable for our Air Flo, we offer you both a halogen and an LED version of our illumination kit with three spotlights each. A unique connection system makes it very easy to install the spotlights on the float. The UST 150 transformer is mounted easily to the pump basket directly.



Air Flo

Set of 3 Halogen	Set of 3 Halogen	Set of 3 LED
3 x Lunaqua 10, each with a 50 W halogen bulb	3 x Lunaqua 10, each with a 50 W halogen bulb	3 x Lunaqua 10 LED, each with a 10 W LED bulb
3 x Light mounting brackets	3 x Light mounting brackets	3 x Light mounting brackets
1 x Special stainless steel holder for fastening the transformer	3 x Special stainless steel holder for fastening the transformer	3 x Special stainless steel holder for fastening the transformer
1 x Safety transformer 150 VA, 230 V-12 V, 50 Hz incl. 20.0 m cable	1 x Safety transformer 150 VA, 230 V-12 V, 50 Hz incl. 50.0 + 2.0 m cable	1 x Safety transformer 150 VA, 230 V-12 V, 50 Hz incl. 50.0 + 2.0 m cable
Order no. 57083	Order no. 50188	Order no. 50479



ILLUMINATION SETS MIDI II / MAXI II



MIDI II illumination sets

For an impressive floating fountain even at night – as easy as our proven Air Flo system, we offer you both a halogen and a LED version of our illumination kit with three spotlights each. A unique connection system makes it very easy to install the spotlights on the float. The UST 150 transformer is mounted easily to the pump basket directly.



MAXI II illumination sets

For an impressive floating fountain even at night – as easy as our proven Air Flo system, we offer you both a halogen and a LED version of our illumination kit with three spotlights each. A unique connection system makes it very easy to install the spotlights on the float. The UST 150 transformer is mounted easily to the pump basket directly.



Set of 3 Halogen		Set of 3 LED		Set of 3 Halogen		Set of 3 LED	
3 x Lunaqua 10, each with a 50 W halogen bulb	3 x Lunaqua 10 LED, each with a 10 W LED bulb	3 x Lunaqua 10, each with a 50 W halogen bulb	3 x Lunaqua 10 LED, each with a 10 W LED bulb	3 x Lunaqua 10, each with a 50 W halogen bulb	3 x Lunaqua 10 LED, each with a 10 W LED bulb	3 x Lunaqua 10, each with a 50 W halogen bulb	3 x Lunaqua 10 LED, each with a 10 W LED bulb
3 x Light mounting brackets	3 x Light mounting brackets	3 x Light mounting brackets	3 x Light mounting brackets	3 x Light mounting brackets	3 x Light mounting brackets	3 x Light mounting brackets	3 x Light mounting brackets
3 x Special stainless steel holder for fastening the transformer	3 x Special stainless steel holder for fastening the transformer	3 x Special stainless steel holder for fastening the transformer	3 x Special stainless steel holder for fastening the transformer	3 x Special stainless steel holder for fastening the transformer	3 x Special stainless steel holder for fastening the transformer	3 x Special stainless steel holder for fastening the transformer	3 x Special stainless steel holder for fastening the transformer
2 x Safety transformer 150 VA, 230 V-12 V, 50 Hz incl. 50.0 + 2.0 m cable	1 x Safety transformer 150 VA, 230 V-12 V, 50 Hz incl. 50.0 + 2.0 m cable	2 x Safety transformer 150 VA, 230 V-12 V, 50 Hz incl. 50.0 + 2.0 m cable	1 x Safety transformer 150 VA, 230 V-12 V, 50 Hz incl. 50.0 + 2.0 m cable	2 x Safety transformer 150 VA, 230 V-12 V, 50 Hz incl. 50.0 + 2.0 m cable	1 x Safety transformer 150 VA, 230 V-12 V, 50 Hz incl. 50.0 + 2.0 m cable	2 x Safety transformer 150 VA, 230 V-12 V, 50 Hz incl. 50.0 + 2.0 m cable	1 x Safety transformer 150 VA, 230 V-12 V, 50 Hz incl. 50.0 + 2.0 m cable
Order no. 50188	Order no. 50479	Order no. 50188	Order no. 50479	Order no. 50188	Order no. 50479	Order no. 50188	Order no. 50479